

MATERIAL HOPPERS

Miniature Handy Hopper

SEE-THROUGH HOPPER WITH REMOVABLE CONE



Miniature Handy Hopper

Material changes are fast, clean and simple with this removable polycarbonate hopper on your processing machine. No tools are needed to quickly hinge the hopper lid out of the way and pull the miniature, see-through hopper cone from the compact frame. A dribble-proof slide gate automatically engages as the hopper is removed, allowing remaining material to be returned to the gaylord, bag or barrel. The mini handy hopper is also an ideal supply hopper above additive feeder throats.

Confirm material flow at the machine throat

Constructed of rugged, clear polycarbonate, the Miniature Handy Hopper provides about a 0.3 cubic feet of material that may be supplied via an automatic loader or hand-filling. The lid closes firmly on the top of the material cone and allows a wide range of loading devices to be installed, then is easily hinged out of the way for hopper access. With the lid safely and automatically locked in the open position, the clear cone may be easily removed using the dual lifting handles.

A level sensing device may be installed in the frame of the hopper to provide a low-material warning or trigger the loader for a controlled material level. A grate magnet may be supplied for the material cone, to catch tramp metal before it can reach the processing machine throat.

The 6 X 6 inch mounting plate accommodates a wide range of custom drilled bolt patterns to match your machine dimensions. Spare cones may be provided as replacements to further enhance quick material changes.

FAST, CLEAN MATERIAL CHANGES

The miniature hopper cone and left-over material may be easily removed from the machine with no tools.

SEE MATERIAL FLOW

The clear polycarbonate hopper allows you to confirm material flow, avoiding costly interruptions and downtime. A sensor may be provided to determine or confirm material level.

HINGED LOADER MOUNT

The rugged lid accommodates an automatic loader which may be hinged and safety-locked out of the way. The lid is pre-drilled and tapped to accept Conair loader models TLM, DL8, and DB8.



SPECIFICATIONS

MATERIAL HOPPERS Miniature Handy Hopper

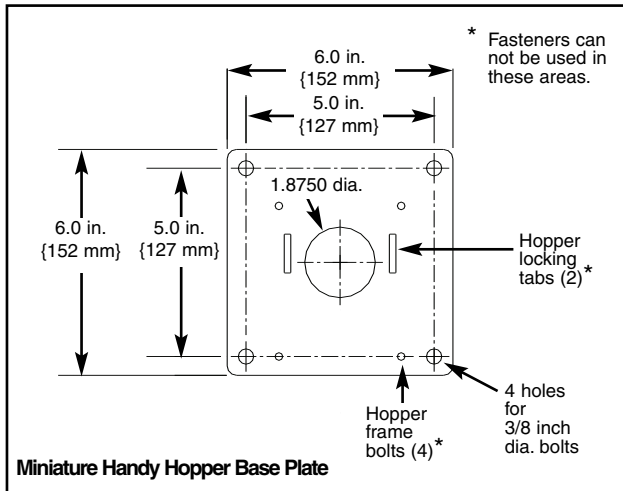
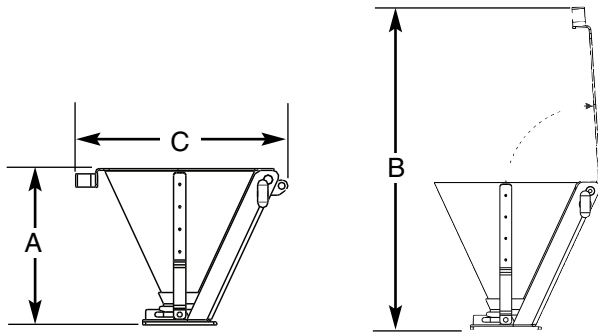

Miniature Handy Hopper Base Plate

Performance characteristics	
Model part number	100 590 02
Capacity in lb (kg) @ 35 lb ft ³	10.5 {4.76}
Capacity in ft ³ (liters)	0.30 {8.5}
Cone construction	Polycarbonate, with aluminum and stainless steel
Maximum material temperature	260° F {127° C}
Maximum loader weight lb {kg}	80 {36}
Maximum loader height inches {mm}	22 {559}
Dimensions inches (mm)	
A - Overall height (lid closed)	12.75 {323.9}
B - Overall height (lid opened)	27.3125 {693.7}
C - Width (at top plate)	14.5 {368.3}
Depth (at top plate)	17.375 {441.3}
Center hole diameter	1.75 {44.5}
Weight lb (kg)	
Installed weight	15 {7}
Shipping weight	18 {8}

SPECIFICATION NOTE:
Specifications may change without notice. Check with a Conair representative for the most current information.

OPTIONS:

Grate Magnet	Part number 294 008
Top Hole Cover	Part number 105 525 38



Compact and visual

The Miniature Handy Hopper's base plate can be easily drilled for nearly any machine throat. The hinged lid provides a sturdy mounting surface for an automatic loader or the lid may be opened for hand-filling. Operators can easily verify material flow.



Easy dump and clean

The clear, rugged, polycarbonate hopper may be easily removed with no spilling or draining, allowing the remaining material to be returned to storage.