

DM-II MODEL, DRYING MONITOR

ASSURE PROPER DRYING FOR DEFECT-FREE PRODUCT



The DM-II Drying Monitor option can save you time and money, and from the aggravation of dealing with improperly dried material.

The DM-II automatically monitors the temperature profile inside your drying hopper within a pre-set temperature band to protect you from overdrying or underdrying your material. A warning alarm shown on the control display and light tower alerts you to improper drying conditions. This advanced notice provides time to diagnose and correct otherwise undetected problems that can lead to defects in products. In addition, the DM-II may be used to tune the dryer process temperature to minimize energy consumption.

NO GUESSWORK, KNOW WHAT'S HAPPENING WITH YOUR DRYING PROCESS

This valuable option can help you uncover common drying problems that may exist, including: a failed or out-of-place process RTD; improperly sized hoppers or dryers; drying or loading equipment failures; reduced airflow caused by dirty filters; kinked hoses and other obstructions; a throughput change; loss of power or overheated material.*

The DM-II is available as an option to the HY packages on Carousel Plus Dryer models W50 and MDCW50 and above. The drying monitor can be fitted to 39 different sized CH, RW or ESH series hoppers. The dryer must have a DC-2 control and be dedicated to a single drying hopper.

A field retrofittable upgrade is available for existing DC-1 controllers.

* The DM-II does not alert you to the specific drying problem, however, the DC-2 control will identify most dryer related faults.

■ Easy to use

The DM-II can be used in automatic mode with just a few simple parameters set by the operator or can be tuned to individual material requirements by adjusting the inputs on several more screens on the DC-2 control.

■ Alerts you to possible drying problems

Any temperature swing above or below the setpoints triggers a related alarm.

■ Integrated into the DC-2 control

DM-II capabilities are built into the DC-2 dryer controller. No stand alone panel, or board interface to contend with.

■ Automated monitoring

The DM-II monitors the temperature profile of the material in the hopper using six Resistance Temperature Device (RTD) sensors. These RTD sensors are located at evenly spaced positions on a probe that has been installed in the drying hopper. Monitoring the six sensors creates an accurate hopper temperature profile. If the temperature moves beyond the high or low setpoints, the DM-II alerts the operator with a passive alarm displayed on the control display and a light tower that lights green during proper operation, amber to indicate possible trouble or red to alert you that the dryer has stopped due to an alarm condition.

■ Trending graphs

When used in conjunction with a ControlWorks or EnergySmart system, the hopper temperature profile is stored to memory for historical trending and fine-tuning of the dryer. This information can be used to help minimize energy consumption.

DM-II MODEL, DRYING MONITOR

DM-II probe specifications

Drying Hopper #	Conair Part #
CH/RW 10-1	1819080101
CH/RW 10-1.5	1819080102
CH/RW 14-2	1819080103
CH/RW 14-3	1819080104
CH/RW 14-4	1819080105
CH 18-4	1819080106
RW 18-5	1819080107
CH/RW 18-6	1819080108
CH 24-8	1819080109
RW 24-9	1819080110
CH/RW 24-12	1819080111
CH/RW 24-15	1819080112
CH/RW 24-18	1819080113
CH/RW 33-21	1819080114
CH/RW 33-28	1819080115
CH/RW 39-35	1819080116
CH/RW 39-42	1819080117
CH/RW 44-58	1819080118
CH 54-70	1819080119
CH 54-85	1819080120
CH 54-99	1819080121
CH 54-114	1819080122
CH 54-129	1819080123
CH 64-158	1819080124
CH 64-187	1819080125
CH 64-215	1819080126
CH 64-248	1819080127
CH 74-245	1819080128
CH 74-366	1819080129
CH 74-487	1819080130

Communication Options

Information produced by the DM-II may be retrieved from the DC-2 control using any one of the following dryer communication options:

- Modbus RTU EIA/RS-232
- Modbus RTU EIA/RS-485
- Modbus RTU Ethernet
- DeviceNet

The DM-II package includes:

- Drying monitoring probe
- Connecting cable
- Pre-wired dryer panel
- Light tower

NOTE: If your dryer does not have a DC-2 control, you will need to purchase a control upgrade.

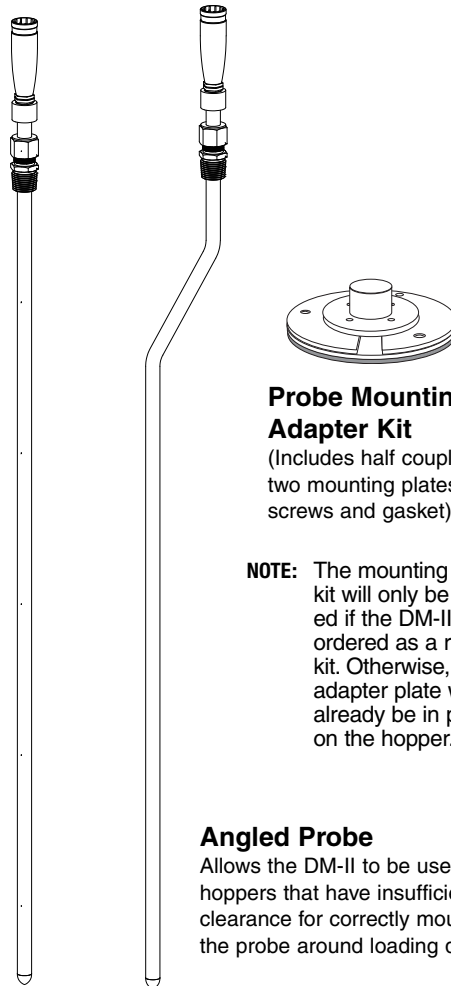

Probe Mounting Adapter Kit

(Includes half coupling, two mounting plates, screws and gasket)

NOTE: The mounting adapter kit will only be included if the DM-II was ordered as a retrofit kit. Otherwise, the adapter plate will already be in place on the hopper.

Angled Probe

Allows the DM-II to be used on hoppers that have insufficient clearance for correctly mounting the probe around loading devices.