

Each Hopper Temperature Controller is equipped with a Heater Box (left) that connects directly to the drying hopper and a precision DC temperature controller (right).

PRECISE CENTRAL DRYING CONTROL

Heat Boosters supply economical drying heat to individual drying hoppers for the most efficient material pre-conditioning system available. With a temperature range up to 350°F {178°C}, and a full complement of safety devices, Heat Boosters are exceptional for providing safe, precise temperatures for drying.

FAST RESPONDING, ENERGY EFFICIENT HEATERS

The HTC Heat Boosters feature tube type heaters with fast responding, energy efficient, open-wire resistance heaters located within mica-lined stainless steel tubes. High temperature safety shut off protection is an integral feature of each HTC.

The HTC controls feature a lockable fused disconnect switch, solid state heater contactor, isolation contactor for over temperature safety protection and a proportioning temperature controller. The temperature is monitored and controlled with a remote sensor located at the hopper air inlet.

- **Individual heating units**
Allows you to heat hoppers individually for your unique drying needs.
- **Precision heat control**
Features dual display of setpoint and actual temperatures.
- **Safe surface temperature**
Insulated heater box ensures safe surface temperature.
- **Safe operation**
Redundant safety switches and alarms help eliminate accidents.

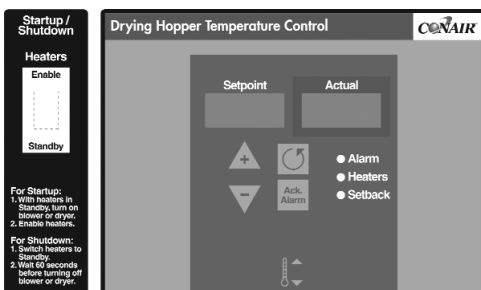

Accurate, safe temperature control

Drying temperatures are set and monitored easily with the DC Control which displays both setpoint and actual temperatures. Over/under temperature and temperature deviation faults are also clearly alerted along with low airflow conditions, which prevent operation during hopper cleaning or without airflow from the central dryer.



SPECIFICATIONS

HOPPER TEMPERATURE CONTROLLERS

HTC FOR CAROUSEL PLUS DRYERS

HTC MODELS, 600 - 5000

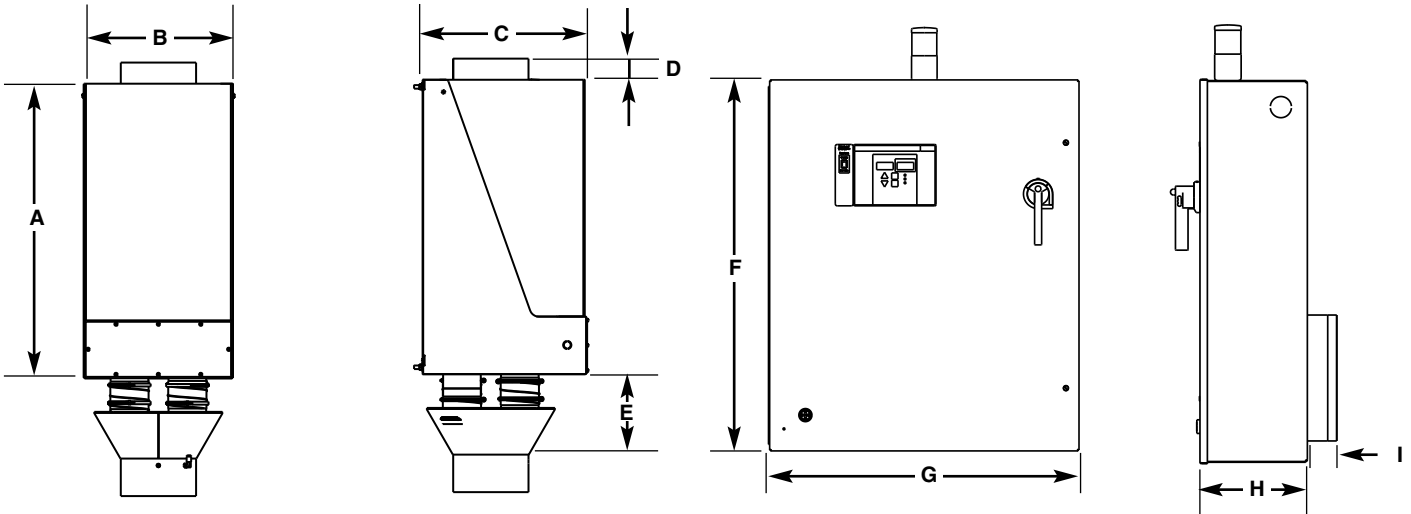

MODEL HTC	HTC-30H*	HTC-60H*	HTC-90H*	HTC-120H*	HTC-180H*	HTC-270H*	
Carousel Plus dryer model	W600	W800 & W1000	W1600	W2400	W3200	W5000	
Performance characteristics							
Temperature range	150° - 375° F {66° - 191° C}						
Flow rate cfm	300	400	500	800	1200	1600	2500
Pressure drop@flow rate inches WC†	3.0	1.8	2.3	4.0	3.8	5.9	6.4
{mm} WC†	{76.2}	{45.7}	{58.4}	{101.6}	{96.5}	{149.9}	{162.6}
Dimensions inches {cm} and weight lb {kg}							
Heater box dimensions							
Inlet size (OD)	8	8	12	12	12	12	
Outlet size selection (OD)	8	8	12	12	12	12	
A - Height	31.4 {79.8}	27.5 {69.9}	27.0 {68.6}	31.0 {78.7}	34.0 {86.4}	36.4 {92.5}	
B - Width	10.1 {25.7}	13.6 {34.5}	16.0 {40.6}	16.0 {40.6}	18.0 {45.7}	24.2 {61.5}	
C - Depth	10.7 {27.2}	10.9 {27.7}	10.9 {27.7}	16.0 {40.6}	17.0 {43.2}	17 {43.2}	
D - Height of discharge nozzle above the heater box	1.75 {4.4}	1.5 {3.8}	2.0 {5.1}	1.0 {2.5}	2.0 {5.1}	1.0 {2.5}	
E - Height of inlet nozzle below the heater box	10.6 {26.9}	7.1 {18.0}	8 {20.3}	10 {25.4}	13 {33.0}	15.4 {39.1}	
Installed weight lb {kg}‡	38 {17}	37 {17}	78 {35}	93 {43}	102 {46}	131 {59}	
Control center dimensions							
Height - F	24.0 {61.0}	24.0 {61.0}	36.0 {91.4}	48.0 {122.0}	60.0 {152.4}	60.0 {152.4}	
Width - G	24.0 {61.0}	24.0 {61.0}	30.0 {76.2}	36.0 {91.4}	42.0 {106.7}	42.0 {106.7}	
Depth - H	10.0 {25.4}	10.0 {25.4}	10.0 {25.4}	10.0 {25.4}	12.0 {30.5}	12.0 {30.5}	
Clearance for heat sink - I	3.0 {7.6}	3.0 {7.6}	3.0 {7.6}	3.0 {7.6}	3.0 {7.6}	3.0 {7.6}	
Installed weight lb {kg}	150.0 {68.0}	150.0 {68.0}	180.0 {81.6}	250.0 {113.0}	consult Conair	consult Conair	
Voltage full load amps							
400V/3 phase/50 Hz	44	87	131	175	261	381	
460 V/3 phase/60 Hz	38	76	114	152	227	340	
575 V/3 phase/60 Hz	30	61	91	122	182	272	

SPECIFICATION NOTES:

* The HTC model number reflects the kilowatts of each unit. For example, HTC-60 has a 60 kilowatt heater.

† The unit of measure WC is water column.

‡ Weights are approximate.

Specifications may change without notice. Consult a Conair representative for the most current information.

