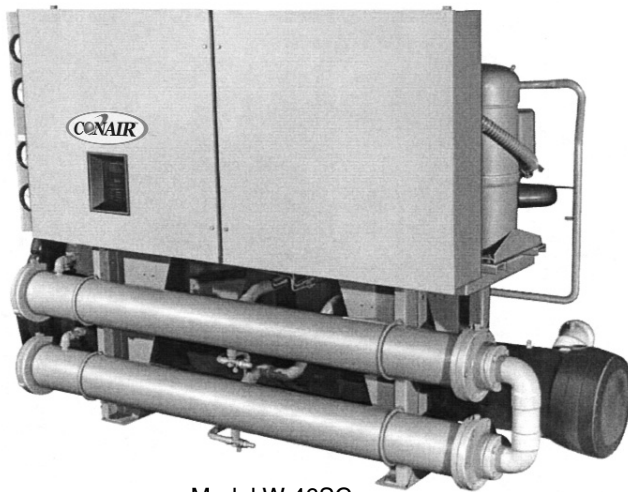

**WATER-COOLED MODELS W-23SC TO W-66SC**

Model W-46SC

# ADVANCED DESIGN FOR EFFICIENT CHILLING

Provide chilled fluid for industrial applications from a central location with the Conair Water-Cooled W-SC series Central Chillers. The simple design of the scroll compressor provides both full load and part load efficiencies unmatched in the industry, and results in lower energy costs when compared to reciprocating compressors.

## NOMINAL CAPACITIES FROM 23 TO 66 TONS

The Conair Water-Cooled W-SC series central chillers are engineered for improved efficiency and better reliability. The scroll compressor is the most advanced compressor in the industry. The unit protects against starting and running overload, under and over voltages, phase loss, phase reversals, high winding temperature and rapid recycling.

The microprocessor control maintains chilled water temperature more accurately, resulting in less temperature drift.

The microprocessor monitors temperature and the rate of change over time, effectively controlling compressor loading for efficient chiller operation.

The scroll compressor's positive displacement design along with staging dual refrigerant circuits result in lower energy costs.

### ■ Rugged scroll compressor

Designed with the most advanced scroll compressor in the industry. There are 70% fewer compressor parts, compared to reciprocating compressors. This means your unit is engineered for a long, reliable life.

### ■ Customized to fit your needs

Conair has the central chiller to match your process. Pick nominal chilling capacities from 23 tons to 66 tons. Larger capacities are available.

### ■ Easy setup

Small unit size, factory wiring, easy lifting procedures and startup control logic result in quick and easy installation. Includes one day of startup services by a factory-trained technician.

### ■ Trouble-free operation

Smart safety features and over 40 diagnostic displays for easy and virtually trouble-free operation.



**WATER-COOLED MODELS W23SC TO W-66SC**

**Easy access controls**

Controls have automatic compressor sequencing, load limiting, and anti-cycle functions.

**Operator interface**

Interface monitors temperature and rate of change over time, effectively controlling compressor loading.

**Dual refrigerant circuits**

Larger chillers have dual refrigerant circuits with two compressors per circuit. Compressors are designed to handle liquid slugging.

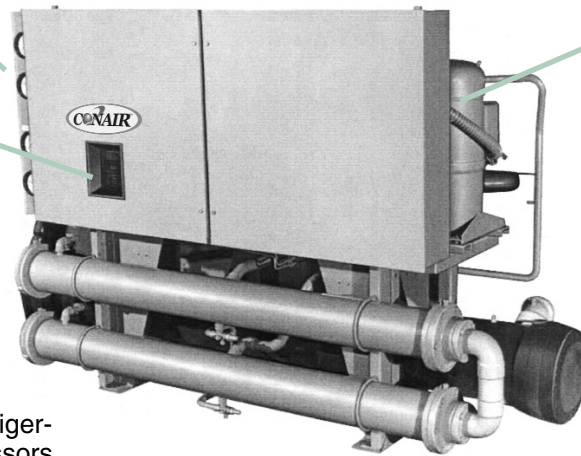

**Scroll compressor**

Compressor has 70% fewer parts compared to reciprocating compressor; direct-drive, low speed for high efficiency and high reliability.

**Energy efficient**

Energy costs are lower when compared with reciprocating compressors.

**Flow switch**

field installed to positively detect flow loss of evaporator solution.

**Evaporator**

Shell-and-tube evaporator is designed with seamless internally finned copper tubes, roller-expanded into tube sheets.

**CONTROL**

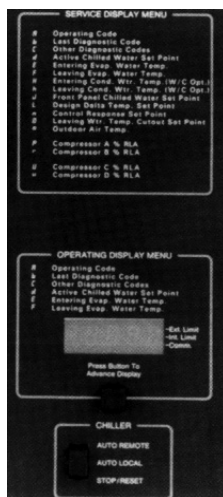

**Panel Display**

- easy-to-use operator interface.
- shows over 40 diagnostic operating and safety codes.
- smart safety features shut down cooling only if absolutely necessary, preventing nuisance safety trip outs.
- factory packaged controls and sensors reduce job site labor costs while assuring proper installation.
- factory tested for smooth startup.

**WATER-COOLED MODELS W23SC TO W-66SC****State-of-art compressor technology**

70% fewer parts than equal capacity reciprocating compressor.

**Resistant to slugging**

Design allows liquid and dirt to pass through without damaging compressor.

**Reduced rotor tip clearance**

Rotor tip results in reduced leakage between the high and low pressure cavities during compression.

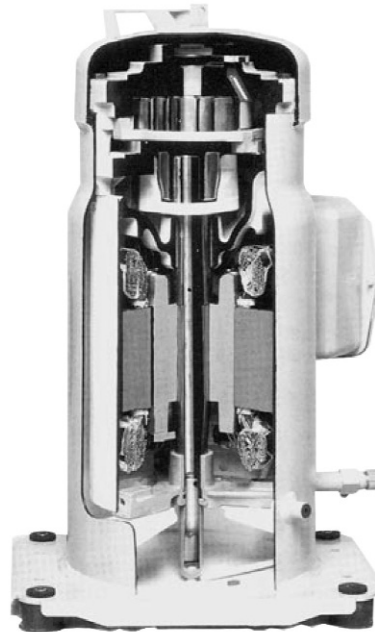

Cutaway of scroll compressor

**One third less torque variations**

Scroll compressor has less than a third the torque variations of a reciprocating compressor.

**Advanced microelectronics**

Microelectronics protects both compressor and motor from typical electrical fault conditions.

**Hermetically sealed**

for reliability.

**OPTIONS****Hot Gas Bypass**

modulates capacity for close temperature control.

**Remote Condenser**

rejects heat to outdoor ambient air.

**Different LWT Ranges**

standard leaving water temperature ranges from 40°F to 60°F {4.4°C to 15.6°C} and optional temperature ranges from 10°F to 25°F {-12.2°C to -3.9°C} and 26°F to 39°F {-3.3°C to 3.9°C}.

**Remote Setpoint**

input for integration into the control system. Choose 0-5VDC or 0-10VDC.

**Water Regulating Valves**

for condenser water lower than 85°F {29.4°C}.

**Compressor Warranty**

choose an additional two- to five-year compressor component replacement warranty.

**Easy Disconnect**

external handle allows local power shut-off to control center.

**Parallel Condensers**

allow partial load during condenser tube-side maintenance.

**WATER-COOLED MODELS W-23SC TO W-66SC**

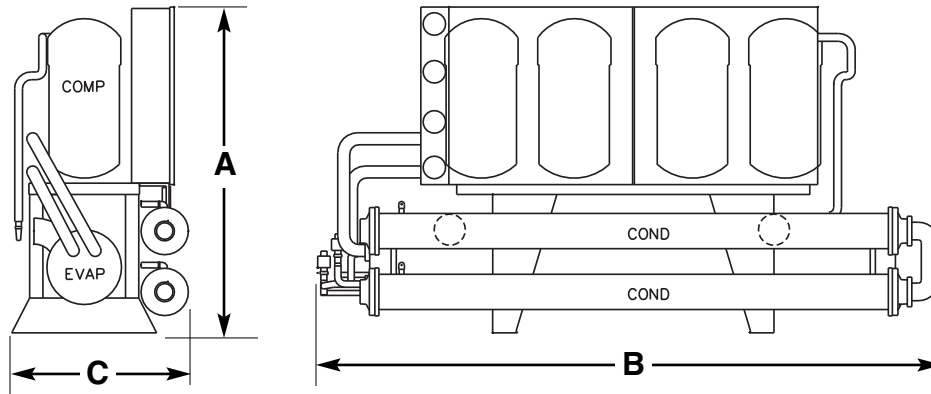

MODEL	W-23SC	W-28SC	W-33SC	W-46SC	W-54SC	W-66SC						
<b>Performance characteristics</b>												
Capacity* tons at 85°F condenser water inlet:												
40°F {4.4°C}	18.4	22.7	27.0	36.4	44.9	55.0						
45°F {7.2°C}	20.2	25.0	29.7	40.1	49.5	60.4						
50°F {10°C}	22.2	27.4	32.6	43.9	54.3	66.0						
55°F {12.8°C}	24.3	29.9	35.6	48.0	59.3	71.9						
60°F {15.5°C}	26.4	32.6	38.8	52.2	64.6	78.0						
Number compressors tons	10,10	10,15	15,15	10,10,10,10	10,10,15,15	15,15,15,15						
Evaporator flow† gpm {lpm}	53.2 {201}	65.6 {248}	78.1 {295}	105.2 {398}	130.0 {492}	158.1 {598}						
Pressure drop‡ psi {bar}	6.8 {0.46}	5.8 {0.39}	3.9 {0.27}	6.7 {0.46}	4.6 {0.32}	10.7 {0.74}						
Condenser water flow gpm {lpm}	63.2 {239}	78.1 {295}	93.1 {352}	125.1 {473}	154.8 {585}	188.8 {714}						
Condenser pressure drop psi {bar}§	7.2 {0.49}	7.2 {0.49}	6.8 {0.46}	7.1 {0.49}	7.1 {0.49}	4.9 {.34}						
<b>Dimensions in (cm)</b>												
A-Height	57.8 {147}	57.8 {147}	57.8 {147}	57.8 {147}	57.8 {147}	74.6 {189}						
B-Width	122.6 {244}	122.6 {244}	122.6 {244}	129.0 {328}	129.0 {328}	108.0 {274}						
C-Length	31.4 {80}	31.4 {80}	32.2 {82}	31.4 {80}	31.4 {80}	34.0 {86}						
Evaporator connections type	2 FPT	2 FPT	2.5 FPT	2.5 FPT	3 FPT	4 GRV						
Condenser connections type	2 FPT	2 FPT	2 FPT	2 FPT	2 FPT	4 GRV						
<b>Weight lb (kg)</b>												
Shipped	1282 {582}	1360 {618}	1774 {806}	2126 {965}	2376 {1079}	3224 {1464}						
Installed	1454 {660}	1517 {689}	2009 {912}	2506 {1138}	2727 {1238}	3753 {1704}						
<b>Utility requirements</b>												
Power consumption, amps (each)**	MCA	RLA	MCA	RLA	MCA	RLA	MCA	RLA	MCA	RLA	MCA	RLA
230V/3 phase/60hz	77	34/34	99	52/34	117	52/52	145	34/34	185	52/34	221	52/52
460V/3 phase/60hz	32	14/14	43	23/14	52	23/23	60	14/14	80	23/14	98	23/23
575V/3 phase/60hz	29	13/13	36	18/13	41	18/18	55	13/13	67	18/13	77	18/18

**SPECIFICATION NOTES**

\* Based on 50°F {10°C} leaving water temperature with 2.4 gpm/ton flow rate and 85°F {27°C} condenser water supply @ 3 gpm/ton flow rate.

† Based on 50°F {10°C} leaving water temperature and 60°F {16°C} returning water temperature.

‡ Not including optional water regulating valves.

§ Evaporator pressure drop at respective nominal flow rate.

\*\*MCA: Minimum circuit ampacity - 125% of the largest compressor RLA plus 100% of the remaining compressor(s) RLA; RLA per compressor.  
RLA: Running load amps. GRV: Groove.

Specifications may change without notice. Check with a Conair representative for the most current information.