

BOLTED STEEL OR ALUMINUM SILOS

LOW COST EXPORTABLE BULK STORAGE

Conair's bolted steel or aluminum silos are shipped unassembled. They can be shipped virtually anywhere in the world and assembled at the customer's plant.

The individual panels of a bolted steel silo are epoxy coated on the inside to keep material contamination free. The outside is primed and enamel coated to prevent rusting. Aluminum panels do not require internal or external painting or coating.

BROAD RANGE OF STORAGE CAPACITIES AVAILABLE

Conair offers bolted silos in a variety of storage capacities ranging from 1,901 to 10,412 cubic feet.

Two cone configurations are available. Configuration is determined by the type of material to be stored. Silos for pellet storage usually have a 45° cone bottom. For powder and hard-to-flow materials the silo includes a 60° cone.

The Conair sales team is ready to help you select the size, style and features that will best suit your storage needs.

Specially trained installation crews assemble the silo on a customer poured pad and connect all accessories and install the unloading and conveying system to get you up and running.

■ **Reduced freight costs**

Because bolted silos are delivered in pieces, they can generally be shipped by commercial carrier.

■ **Customized to fit your needs**

Options include a safety cage and rest platform for silos over 30 feet, a ladder and a slide gate shut-off which is pre-drilled to accept an optional Conair distribution box.

■ **Many standard features**

Included as standard are a prefabricated roof with manhole/vent combination, perimeter guard rail with safety toe board and railing. Also, a vacuum receiver mounting flange, truck-fill nipple, ladder, high and low level indicator mounts, mounting flange for the slide gate shut-off, a fully enclosed weather-proof vented silo skirt, and a louvered access door in the skirt of the silo is included. If two or more silos are purchased at once, a four foot (span) crossover walkway is provided.

BOLTED STEEL OR ALUMINUM SILOS

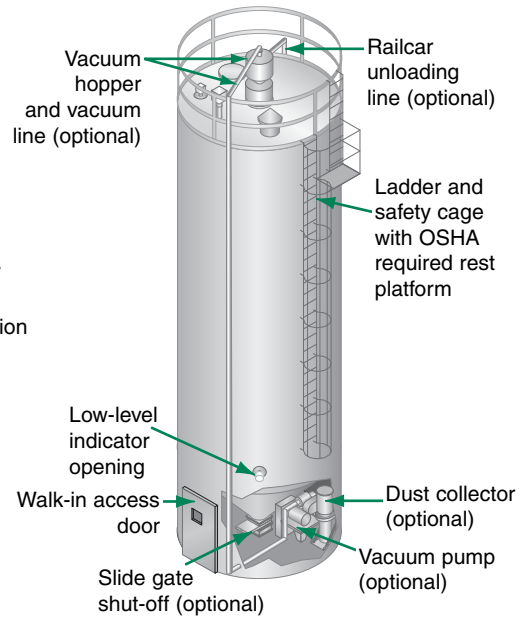
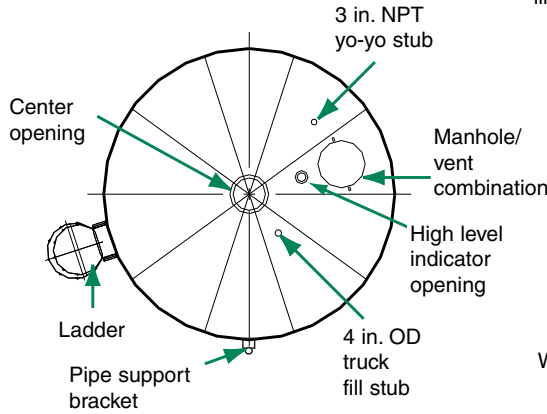
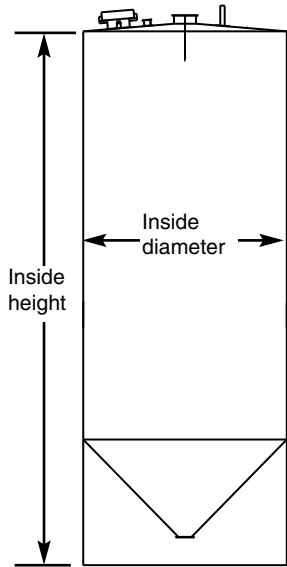

SB MODELS												
Inside diameter	12 ft, 3 11/16 in						15 ft, 4 5/8 in					
Silo inside height in. {m} *	24 {7.3}	32 {9.8}	40 {12.2}	48 {14.6}	56 {17.1}	64 {20.0}	24 {7.3}	32 {9.8}	40 {12.2}	48 {14.6}	56 {17.1}	64 {20.0}
Performance characteristics												
Silo capacity 45° cone ft³ {liters} †	1901 {53836}	2851 {80740}	3802 {107673}	4752 {134577}	5703 {161509}	6653 {188412}	2923 {82779}	4421 {125203}	5919 {167626}	7416 {210021}	8914 {252444}	10412 {294868}
Construction material	ASTM A570 Grade 40 Steel or 5052 - H-32 Aluminum											
Wind load	100 mph											
Snow load	40 lbs/ft²											
Weight lbs {kg} ‡												
Shipping (empty)	6064 {2750}	7616 {3454}	9168 {4159}	10840 {4917}	13136 {5958}	15352 {6963}	9257 {4199}	10977 {4979}	13757 {6240}	16337 {7410}	18787 {8522}	22477 {10195}
Full to capacity	82104 {37242}	121656 {55182}	161248 {73141}	200920 {91136}	241256 {109432}	281472 {127673}	126177 {57233}	187817 {85192}	250517 {113633}	312977 {141964}	375347 {170254}	438957 {199107}

SB MODELS						
Inside diameter	18 ft, 5 9/16 in					
Silo inside height in. {m} *	24 {7.3}	32 {9.8}	40 {12.2}	48 {14.6}	56 {17.1}	64 {20.0}
Performance characteristics						
Silo capacity 45° cone ft³ {liters} †	3657 {103566}	5871 {166267}	8085 {228967}	10299 {291668}	12513 {354368}	14727 {417069}
Construction material	ASTM A570 Grade 40 Steel or 5052 - H-32 Aluminum					
Wind load	100 mph					
Snow load	40 lbs/ft²					
Weight lbs {kg} ‡						
Shipping (empty)	13049 {5919}	16145 {7323}	18473 {8379}	22901 {10387}	26312 {11935}	30536 {13851}
Full to capacity	159329 {72270}	250985 {113845}	341873 {155071}	434861 {197249}	526832 {238967}	619616 {281052}

SPECIFICATION NOTES:

* For overall height add 43 inches to inside height to account for the guard rail.

† Cones are available in 45° for pellets, except PET; 60° for powdered materials and PET materials. Reduce silo capacity for 60° cone. 12 feet, 3 11/16 inches, subtract 289 ft³; and 15 feet, 4 5/8 inches, subtract 592 ft³; and 18 feet, 5 9/16 inches subtract 1,272 ft³.

‡ Weight is based on 40 lb/ft³ materials.

Roof live and dead load design is 25 lb per square foot.

Reference foundation drawings: 12 feet, 3 11/16 inches bolted, 501-207 series; 15 feet, 4 5/8 inches bolted, 501-209 series; and 18 feet, 5 9/16 inches bolted, 501-217 series.

Specifications may change without notice. Check with a Conair representative for the most current information.