

PORTABLE CHILLERS**Series 1 Water- and Air-Cooled Models**

Model A1-5

PORTABLE MACHINE-SIDE COOLING IN TWO MODELS

The Conair Series 1 Portable Chillers provide self-contained sources of chilled water and are available in either water- or air-cooled models.

These small, moveable units are ideal for machine-side cooling. They can be used anywhere you need a reliable source of process cooling water and stable temperature control.

From 1.5 to 15 tons nominal cooling capacity

These totally self-contained chillers are designed to provide chilled water for industrial applications requiring 24-hour-a-day performance.

Ranging in size from 1.5 Hp to 13 Hp for the air-cooled models and 1.5 Hp to 15 Hp for the water-cooled design, nominal capacities range from 1.5 tons to 15 tons of refrigeration. Pump selections are available to match most process flow and pressure requirements. All wetted parts are non-ferrous.

The normal temperature range of discharge chilled water is 20 °F to 70 °F. For applications requiring 40 °F or lower, a glycol mixture can be used.

Both A1 and W1 units are available with either a simple-to-operate TIC control or a full-function PLC control with automatic tuning for precise temperature control.

■ **STATE-OF-THE-ART CONTROLS**

The easy-to-use controls display process status information, as well as let you change settings quickly. Choose the TIC control for simple monitoring, or select the PLC control with automatic PID fine tuning for uniform temperature control regardless of light or heavy external loading.

■ **CHOOSE FROM TWO DESIGNS**

Choose the air-cooled A1 model for maximum portability. The water-cooled W1 model is ideal for use with tower water, or another inexpensive water source. Both models can operate almost anywhere.

■ **WIDE RANGE OF USES**

These chillers are useful for cooling injection molding, blow molding, thermoforming, extrusion, air compressors, metal plating, anodizing, degreasing, heatset/web offset printing presses and dryer after-coolers. Use anywhere a reliable source of process cooling water - with stable temperature control - is required.

■ **YOUR CHOICE OF PUMPS, VOLTAGE**

Conair matches your process flow and pressure requirements to the proper pump size. All standard voltages are available. Electrical panels and instrumentation all use UL, CSA, and CE listed components.

FEATURES

PORTABLE CHILLERS
Series 1 Water- and Air-Cooled Models

Hot gas bypass valve

Permits efficient operation with cooling loads as low as 25% of rated chiller capacities. The valve balances the load on the chiller, while providing tight temperature control.

PVC and aluminum frame

Rust-proof, PVC body panels and aluminum frame provide rugged support.

Water connections

Convenient condenser and chilled water connections.

Pump tank

Welded stainless steel tank allows installation of overhead piping. Low-water level sensors, external fill ports and level indicators are standard.

Copeland® compressors

Reciprocating compressor for sizes up to 5 Hp, and scroll compressor for sizes 7.5 Hp and larger.

Performance-engineered condensers

Water-cooled models are equipped with high efficiency, non-ferrous tube-in-tube condensers and water regulating valves. Air-cooled models have aluminum fin, copper tube condensers and automatic fan cycling controls.

Process pump

Stainless steel construction circulates fluid through the chiller.

Electrical components

Series 1 models use all UL, CSA, and CE listed components.

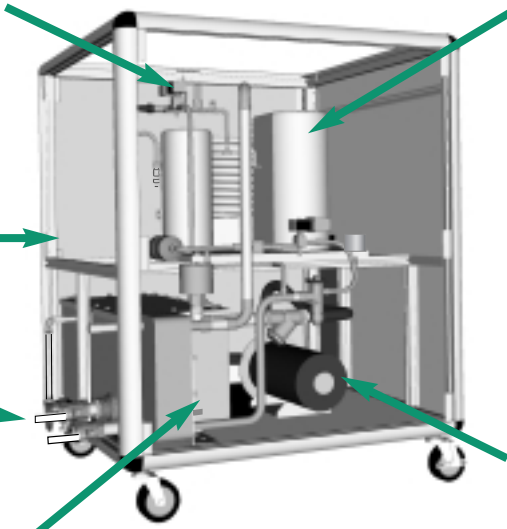

CONTROLS

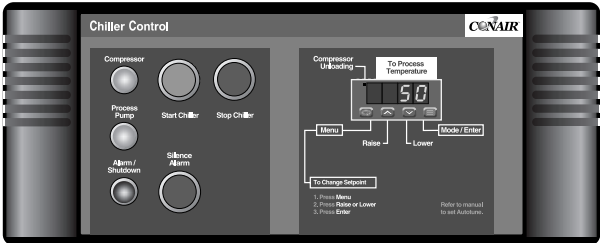

TIC control

This inexpensive control provides simplified, accurate process fluid temperature control. Standard features include:

- Quick, one-button starting and stopping.
- Simple entry of process temperature setpoint.
- Status lights that indicate when compressor, pump, and alarm are activated.
- Four-digit LED display shows current To Process temperature, settings and run modes.



PLC control

This operator friendly control is full-featured and and flexible. Standard features include:

- Automatic fine-tuning of PID control parameters for uniform temperature control regardless of external loading.
- A two-line LCD display that indicates actual and setpoint temperatures, percent loading, refrigerant pressures, run status, alarms and diagnostic information.
- Indicator lights that show when compressor, pump, and alarm are activated.
- Pump down capabilities to prevent refrigerant migration and prolong the life of the chiller.
- Password entry to prevent unauthorized or accidental changes to operating parameters.
- Optional remote control up to 50 feet away.



SPECIFICATIONS

PORTABLE CHILLERS
Series 1 Water-Cooled Models

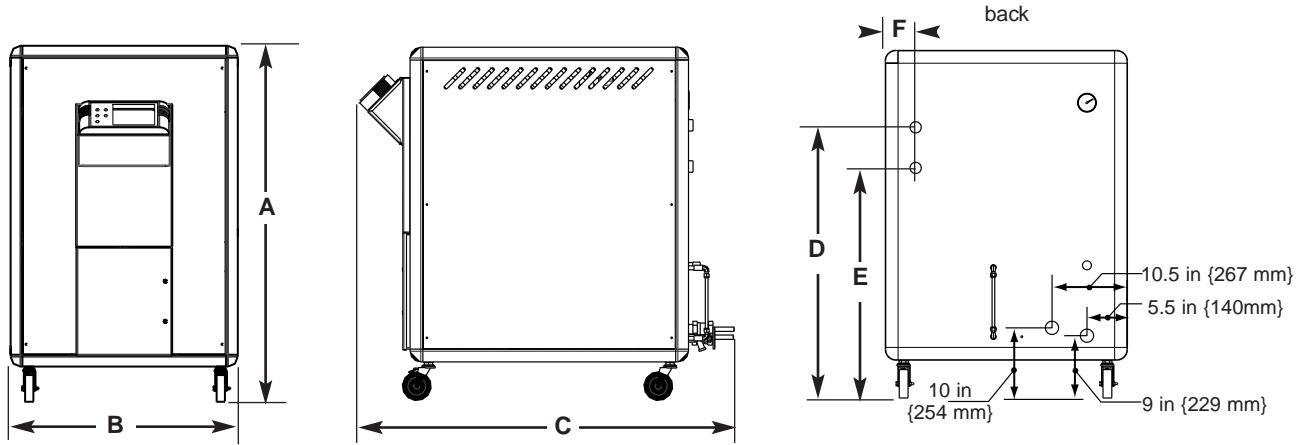

MODEL	W1-1.5	W1-2	W1-3	W1-4	W1-5	W1-7.5	W1-10	W1-15								
Performance characteristics																
Capacity* tons	1.44	1.93	3.23	4.44	5.00	7.09	10.22	14.68								
Compressor Hp {kW}	1.5 {1.1}	2 {1.5}	3 {2.2}	4 {3}	5 {3.7}	7.5 {5.6}	10 {7.5}	15 {11}								
Pump Hp {kW}																
60 Hz	0.75 {0.6}	0.75 {0.6}	1 {0.8}	1 {0.8}	1.5 {1.1}	1.5 {1.1}	1.5 {1.1}	2 {1.5}								
50 Hz	1.5 {1.1}	1.5 {1.1}	1.5 {1.1}	2 {1.5}	2 {1.5}	2 {1.5}	2 {1.5}	2 {1.5}								
Chilled water flow† gpm {l/min}	6.9 {25.1}	4.6 {17.4}	7.8 {29.5}	10.7 {40.5}	12.0 {45.4}	17.0 {64.3}	24.5 {92.7}	35.2 {133.2}								
Chilled water pressure‡ psi {bar}	27.8 {1.9}	29.9 {2.1}	32.9 {2.3}	31.8 {2.2}	41.6 {2.9}	34.8 {2.4}	29.3 {2.0}	32.3 {2.2}								
Reservoir capacity gal {l}	8.0 {30.3}	15 {57}	15 {57}	15 {57}	15 {57}	25 {95}	25 {95}	25 {95}								
Condenser water flow gpm {l/min}	5.0 {18.9}	6.4 {24.2}	10.3 {39.0}	14.2 {53.7}	16.7 {63.2}	24.1 {91.2}	31.7 {120}	45.4 {172}								
Dimensions in {mm}																
A - Height	49 {1245}				49 {1245}		61 {1549}									
B - Width	34 {864}				34 {864}		34 {864}									
C - Length	39.5 {1003}				45.5 {1156}		55 {1397}									
D - Height to condenser out	37 {940}	38.5 {978}	38.5 {978}	38.5 {978}	38 {965}	41.3 {1049}	41.3 {1049}	41.3 {1049}								
E - Height to condenser in	31 {787}	32.5 {826}	32.5 {826}	32.5 {826}	32 {813}	35 {889}	35 {889}	35 {889}								
F - Distance to valves	4 {102}				4.5 {114}											
Weight lb {kg}																
Installed	420 {190}	585 {265}	585 {265}	840 {381}	840 {381}	1080 {490}	1090 {494}	1095 {497}								
Shipping	550 {249}	755 {342}	755 {342}	1010 {458}	1010 {458}	1250 {567}	1260 {572}	1265 {574}								
Voltages running/full load amps §																
	run	full	run	full	run	full	run	full	run	full	run	full	run	full		
208V/3 phase/50hz	13.1	19.1	13.8	19.4	17.8	27.5	22.5	33.6	24.3	38.6	31.3	47.4	37.4	59.1	46.8	82.1
230V/3 phase/60hz	9.5	15.3	10.2	15.6	15.1	24.4	18.7	29.4	22.5	36.3	29.2	44.7	35.0	56.0	44.8	79.0
460V/3 phase/60hz	4.5	6.9	4.9	7.1	7.3	11.1	9.1	13.3	10.9	16.4	14.2	20.2	17.1	25.3	22.0	35.7
575V/3 phase/60hz	3.6	5.5	3.9	5.7	5.8	8.9	7.3	10.7	8.7	13.1	11.4	16.2	13.7	20.2	17.6	28.5
Utility requirements																
Process connections NPT inches					1						1.5					
Condenser water NPT inches					1						1.5					

SPECIFICATION NOTES

† Based on 50°F (10°C) water temperature (100% water) leaving the chiller, standard pump selections, 85°F (27°C) condenser water supply @ 25 psi minimum, for the 60 Hz units. For the 50 Hz units, multiply the capacity by 0.8. Consult factory for other conditions. Capacity ratings are (±) 5% based on compressor manufacturer's ratings and are subject to change without notice.

‡ Based on 50°F (10°C) water temperature leaving the chiller and 60°F (16°C) water temperature returning to the chiller (except W1-1.5, which has 55°F (13°C) water temperature returning to the chiller).

§ Pressure at pump discharge.

§ Standard voltage is 230V and 460V/3 Phase/60Hz. All other voltages are optional.



SPECIFICATIONS

PORTABLE CHILLERS Series 1 Air-Cooled Models

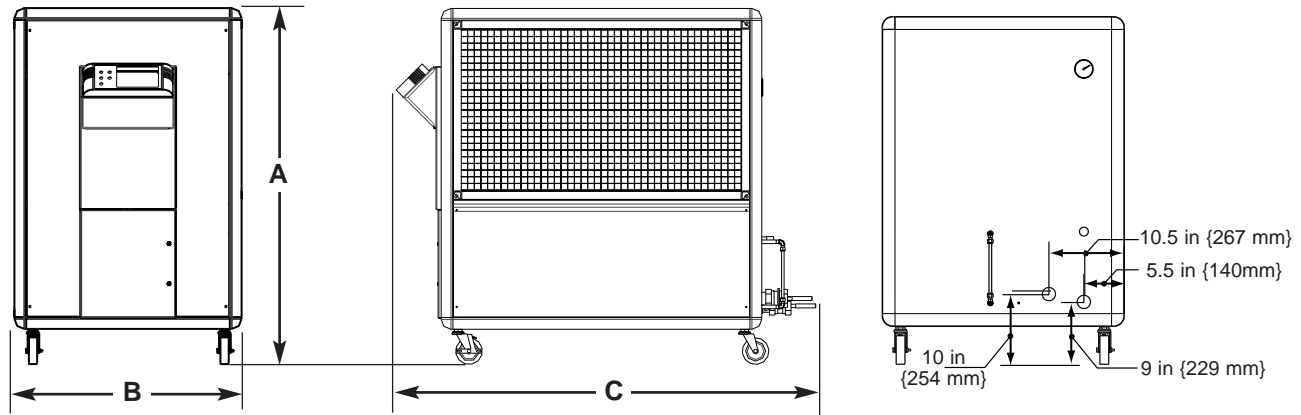

MODEL	A1-1.5	A1-2.25	A1-3.25	A1-4	A1-5	A1-7.5	A1-10	A1-13								
Performance characteristics																
Capacity* tons	1.18	1.79	2.77	3.62	4.27	6.06	8.75	10.95								
Compressor Hp {kW}	1.5 {1.1}	2.25 {1.7}	3.25 {2.4}	4.0 {3.0}	5.0 {3.7}	7.5 {5.6}	10.0 {7.5}	13 {9.75}								
Pump Hp {kW}																
60 Hz	0.75 {0.6}	0.75 {0.6}	1.0 {0.8}	1.0 {0.8}	1.5 {1.1}	1.5 {1.1}	1.5 {1.1}	2.0 {1.5}								
50 Hz	1.5 {1.1}	1.5 {1.1}	1.5 {1.1}	2.0 {1.5}	2.0 {1.5}	2.0 {1.5}	2.0 {1.5}	2.0 {1.5}								
Chilled water flow [†] gpm {l/min}	5.7 {21.6}	8.6 {32.6}	6.7 {25.4}	8.7 {32.9}	10.2 {38.6}	14.5 {54.9}	21.0 {79.5}	26.3 {99.6}								
Chilled water pressure [‡] psi {bar}	29.6 {2.0}	28.5 {2.0}	35.9 {2.5}	33.9 {2.3}	42.4 {2.9}	36.9 {2.5}	31.6 {2.2}	36.1 {2.5}								
Reservoir capacity gal {l}	8.8 {33.3}	15 {57}	15 {57}	15 {57}	15 {57}	25 {95}	25 {95}	25 {95}								
Number of condenser fans	1	2	2	2	2	2	2	4								
Condenser fan power Hp {kW}	0.17 {0.13}	0.17 {0.13}	0.17 {0.13}	0.25 {0.19}	0.25 {0.19}	0.5 {0.4}	0.5 {0.4}	0.5 {0.4}								
Condenser air flow ft ³ /min {l/sec}	1050 {496}	1704 {804}	2420 {1142}	4237 {2000}	4237 {2000}	5300 {2501}	5300 {2501}	9800 {4625}								
Dimensions in (mm)																
A - Height	49 {1245}	49 {1245}		53.5 {1359}		71 {1524}		75 {1905}								
B - Width	34 {864}	34 {864}		34 {864}		34 {864}		34 {864}								
C - Length	39.5 {1003}	45.5 {1156}		55 {1397}		55 {1397}		55 {1397}								
Weight lb {kg}																
Installed	610 {277}	830 {376}	830 {376}	1030 {467}	1030 {467}	1230 {558}	1230 {558}	1440 {653}								
Shipping	750 {340}	1000 {454}	1000 {454}	1200 {544}	1200 {544}	1400 {635}	1600 {726}	1800 {816}								
Voltages running/full load amps [§]																
	run	full	run	full	run	full	run	full	run	full	run	full	run	full		
208V/3 phase/50hz	14.7	23.6	17.1	24.8	21.5	35.5	27.7	37.6	29.9	42.6	41.2	50.0	50.2	66.1	60.0	79.9
230V/3 phase/60hz	11.0	19.6	13.3	20.8	18.6	32.2	23.7	33.3	27.8	40.1	38.6	47.2	47.2	62.7	57.4	76.9
380-420V/3 phase/50hz	7.7	11.8	9.0	12.4	11.4	17.8	14.8	18.8	16.0	21.3	22.2	25.0	27.2	33.0	32.6	40.0
460V/3 phase/60hz	5.3	8.9	6.5	9.4	9.0	14.6	11.6	15.1	13.5	18.2	18.9	21.4	23.2	28.4	28.3	34.8
575V/3 phase/60hz	4.2	7.1	5.2	7.5	7.2	11.7	9.3	12.1	10.8	14.5	15.1	17.1	18.6	22.7	22.6	27.8
Utility requirements																
Process connections, NPT inch	1				1.5											

SPECIFICATION NOTES

* Based on 50°F (10°C) water temperature (100% water) leaving the chiller, standard pump selections, 95°F (35°C) ambient air conditions for the 60 Hz units. For the 50 Hz units, multiply the capacity by 0.8. Consult factory for other conditions. Capacity ratings are (±) 5% based on compressor manufacturer's ratings and are subject to change without notice.

† Based on 50 °F (10°C) water temperature leaving the chiller and 60°F (16°C) water temperature returning to the chiller (except A1-1.5 and A1-2.25, which have 55°F (13°C) water temperature returning to the chiller).

‡ Pressure at pump discharge.

§ Standard voltage is 230V and 460V/3 Phase/60Hz. All other voltages are optional.